

BR 511 501/BR 511 701

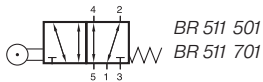

Heavy-duty 5/2-way roller-lever spool valve with mechanical spring. High flow especially for the trucking and railway industry. Lever-construction has proven capabilities in railway applications for decades.

Normally open from 1 to 2 and 4 to 5.
Operated open from 1 to 4 and 2 to 3.

Exhaust can be throttled.

On request:
Roller-lever valves with idle return.

Low temperature version:
In this case the ports are not interchangeable, standard:
Pressure at port 1 = normally closed, normally open version to be ordered separately.

Valves can be used for technical vacuum too.

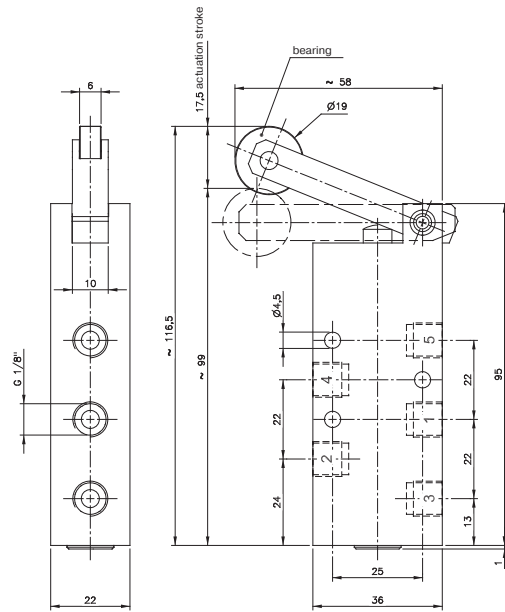

BR 511 501

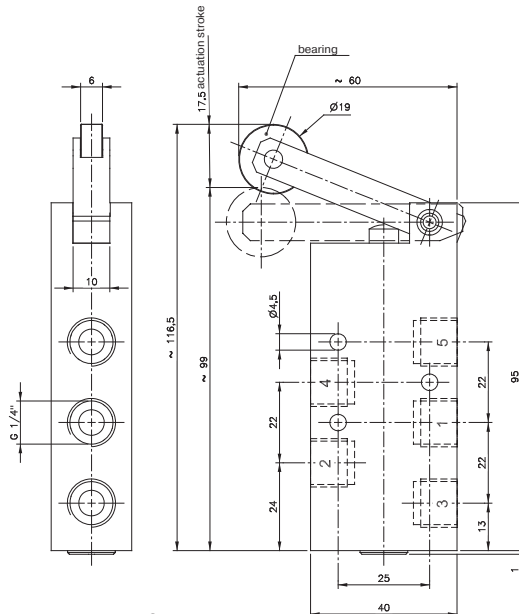

BR 511 701

Also available with a short stainless steel lever. Actuating force is around 9 N.

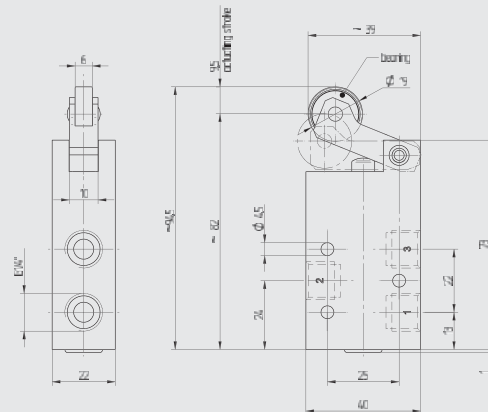

Type	Port size	Air flow	Operating press.	Actuating force	Weight
BR 511 501	G 1/8"	650 l/min	1 - 10 bar	3,5 N	0,23 kg
BR 511 701	G 1/4"	1250 l/min	1 - 10 bar	3,5 N	0,25 kg

