

PN 411 711/MNEH 411 711

Pneumatically and electrically actuated block and block valve

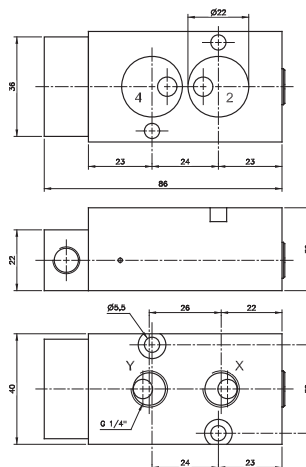
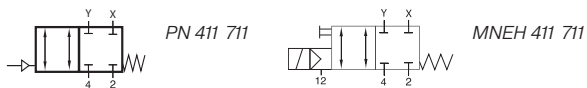

PN 411 711

Valve blocks signals from pilot valve and offers a so-called „stay-put“ or „fail-in-place“ function.

Intermediate valve for assemblage onto the actuator with 1/4" NAMUR-interface. It offers a 1/4" NAMUR-interface towards the pilot-valve (use as sandwich) as well as G 1/4" ports (piped application).

Function:

As long as the valve is actuated, it forwards the signals from the pilot valve which are applied to port X and Y through to 2 and 4. As soon as the actuating signal is taken away or cuts off all ports will be blocked.

Valves can be also used in combination with a positioner.

- PN 411 711 operated by air.
- MNEH 411 711 operated by solenoid and additional external pilot air supply. Equipped with manual override to turn.

MNEH 411 711 available with solenoid operators: 230V/50Hz, 110V/Hz, 24V/50 Hz, 48V=, 24V=, 12V=.

Delivery includes 2 screws, 2 O-rings.

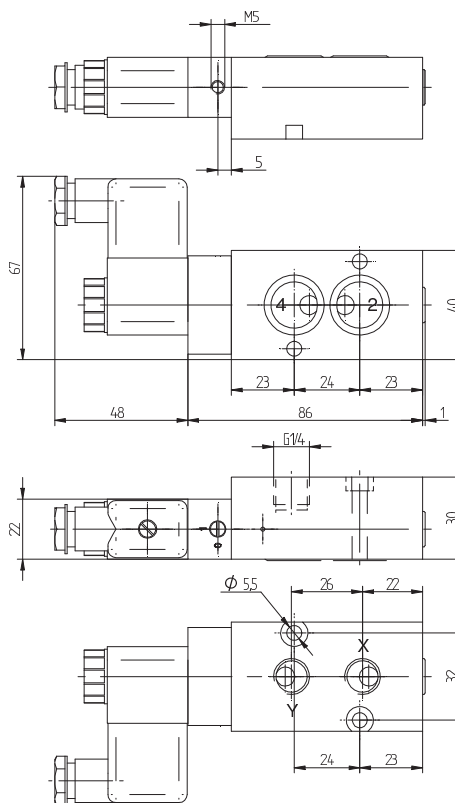

MNEH 411 711

Type	Port size	Air flow	Operating press.	Actuation press.	Power cons.	Weight
PN 411 711	G 1/4" - 1/4" NAMUR	1250 l/min	1 - 10 bar	3 - 10 bar		0,27 kg
MNEH 411 711	G 1/4" - 1/4" NAMUR	1250 l/min	1 - 10 bar	3 - 10 bar (port 12)	3 W = / 5 VA ~	0,35 kg