

PN 411 721/BHN 420 701

Short-cut valve when using manual gearbox



Intermediate valve for assemblage onto the actuator with 1/4" NAMUR-interface. Blocks signals from pilot-valve and short-cuts both actuator chambers. It offers a 1/4" NAMUR-interface towards the pilot-valve (use as sandwich plate) as well as ports G 1/4" for piped application.

Delivery includes 2 screws, 2 O-rings.

Function PN 411 721

As long as a pneumatic signal is applied, the valve forwards the signals applied to 2 an 4 through to X and Y. When no pneumatic signal is applied the ports 2 and 4 are shortcut.

On request:

Valve that is normally blocked, type PN 411 711.

Function BHN 420 701

As long as the knob is pulled, the valve forwards the signals applied to 2 an 4 through to X and Y. When knob is pushed the ports 2 and 4 are shortcut.

Typical application

On automated process-valve equipped with a gear-box for manual actuation in case of emergency.

When failure occurs, compressed air might get trapped in the actuator. Manual operation might damage the actuator. Valve assures, that the user doesn't have to close the process valve against the force of the air.

Version with 1/2" NAMUR-interface available on request.

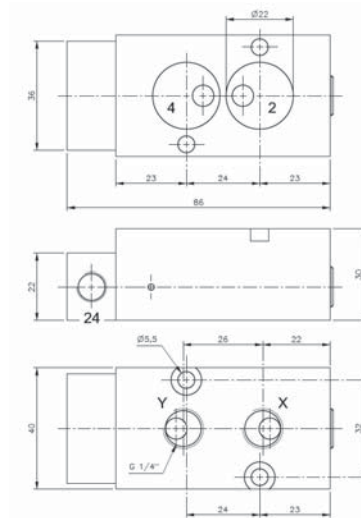

PN 411 721

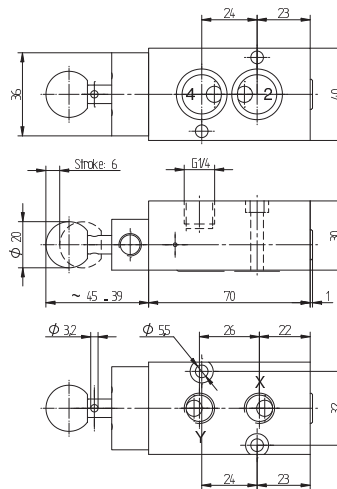

BHN 420 701

Type	Port size	Air flow	Operating press.	Actuating press.	Actuating Force	Weight
PN 411 721	G 1/4"-1/4" NAMUR	1250 l/min	1,5 - 10 bar	3 - 10 bar		0,20 kg
BHN 420 701	G 1/4"-1/4" NAMUR	1250 l/min	1 - 10 bar		18 N	0,22 kg