

# UB 701

Air-recirculation block for single acting actuators

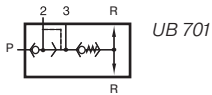

The air-recirculation block guarantees, that only exhausting air from the actuation chamber is going into the spring chamber, no ambient atmosphere is sucked-in.

Valve is designed for spring return pneumatic actuators with 1/4" NAMUR-interface to be controlled by a remote piloted 3/2-way valve.

Standard with G 1/4" pilot port. Materials being used:

- Body: aluminum
- Diaphragm: NBR
- Other inner parts: brass

One of the two exhaust ports 3 to be closed by a plug.

Delivery includes 2 screws, 2 O-rings, 1/4" plug for port 3.

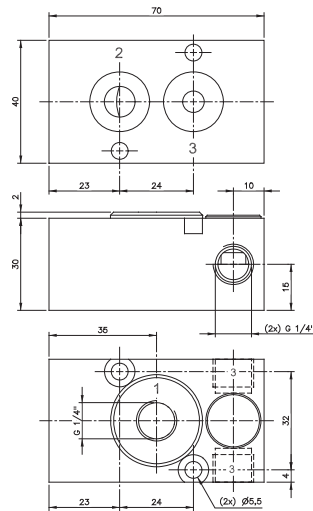

**UB 701**

Function:

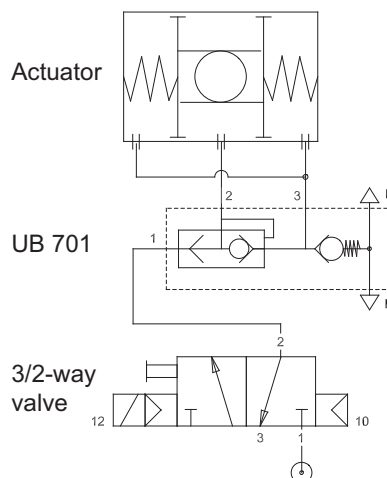

Type	NAMUR	Port size	Air flow	Operating pressure	Weight
UB 701	1/4"	G 1/4"	1250 l/min	1 - 10 bar	0,22 kg

