

MH 510 714 B/MH 510 714 BT MH 520 714 B/ MH 520 714 BT

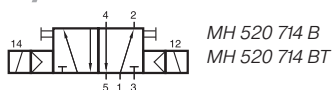
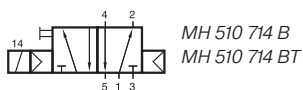

5-way solenoid valve with standardized interface which is widely used in packaging machines for bulk materials such as cement.

Type 510 5/2-way single solenoid, with air spring return
Type 520 5/2-way double solenoid, actuated by impulse

Type B For manifold assembly
Type BT For valve terminal assembly, including intermediate plate type ZP 714 BT

Available with solenoid operators:
230V/50Hz, 110V/50Hz, 48V/50Hz, 24V/50 Hz, 24V=, 12V=.

Valves are generally equipped with manual override.

Mounting screws and seals are included.

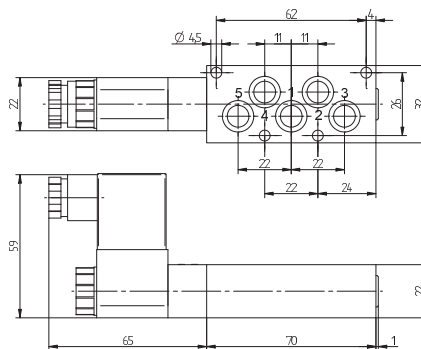

MH 510 714 B

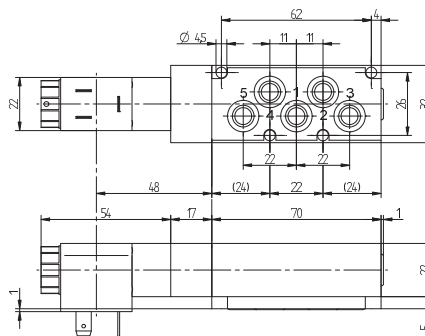

MH 510 714 BT

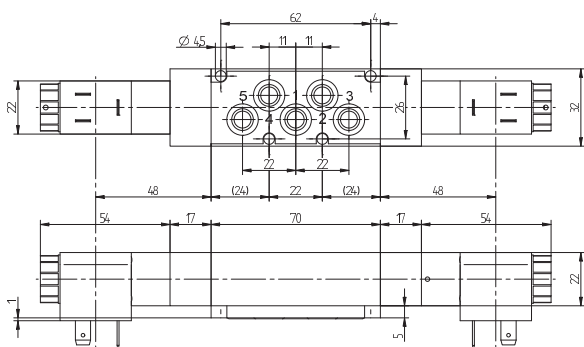

MH 520 714 BT

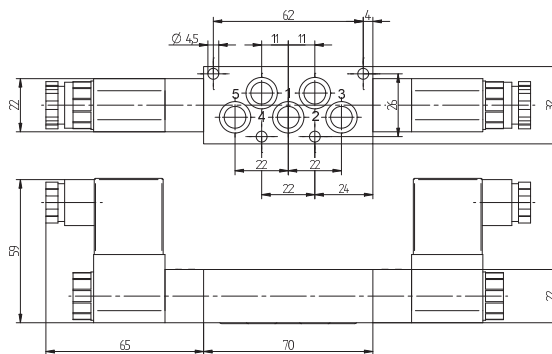

MH 520 714 B

Type	Usage	Port size	Air flow	Operating press.	Power cons.	Weight
MH 510 714 B	Manifold	Ø 7 mm	1250 l/min	2 - 10 bar	3 W = / 5 VA ~	0,20 kg
MH 520 714 B	Manifold	Ø 7 mm	1250 l/min	2 - 10 bar	3 W = / 5 VA ~	0,29 kg
MH 510 714 BT	Valve Terminal	Ø 7 mm	1250 l/min	2 - 10 bar	3 W = / 5 VA ~	0,30 kg
MH 520 714 BT	Valve Terminal	Ø 7 mm	1250 l/min	2 - 10 bar	3 W = / 5 VA ~	0,44 kg