

ARTICULO: 2529

Válvula de esfera paso total Bridada, Acero Inoxidable Stainless Steel full port ball valve, Flanged ends

Características

1. Válvula de esfera paso total, 2 piezas.
2. Extremos Bridados según EN 1092 PN 40.
3. Construcción en Acero Inoxidable 1.4408 (CF8M).
4. Longitud entre caras según EN 558 serie 27.
5. Asientos PTFE + 15 % F.V.
(otro material consultar)
6. Tórica en el eje de FPM (Viton).
7. Vástago inexpulsable.
8. Montaje actuador directo según ISO 5211
9. Sistema de bloqueo incorporado.
10. Dispositivo Anti-estático.
11. Diseño anti-fuego.
12. Presión de trabajo máxima 40 bar.
13. Temperatura de trabajo $-30\text{ }^{\circ}\text{C} + 180\text{ }^{\circ}\text{C}$.

Features

1. Full port ball valve, 2 pieces.
2. Flanged ends according to EN 1092 PN 40.
3. Made of Stainless Steel 1.4408 (CF8M).
4. Face to Face according to EN 558 series 27.
5. Ball seats PTFE + 15 % G.F.
(please ask for other materials)
6. FPM (Viton) stem O' ring.
7. Blow-out proof stem.
8. Direct mounting actuator according to ISO 5211.
9. Block System included.
10. Anti-static device.
11. Fire-safe design.
12. Max. Working pressure 40 bar.
13. Working Temperature $-30\text{ }^{\circ}\text{C} + 180\text{ }^{\circ}\text{C}$.

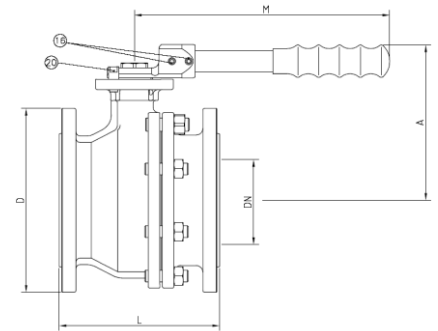
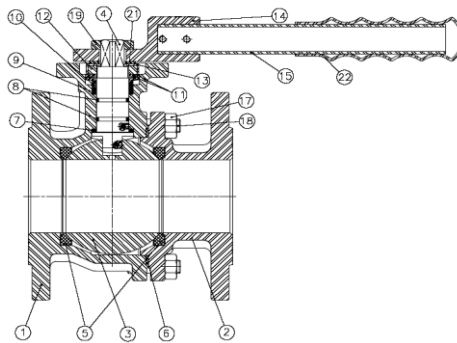

Nº	Denominación / Name	Material	Acabado Superficial / Surface Treatment	Cód. Recambio Spare Part Code
1	Cuerpo / Body	Acero Inox. / Stainless Steel 1.4408	Granallado / Shot blasting	-----
2	Tapa / Cap	Acero Inox. / Stainless Steel 1.4408	Granallado / Shot blasting	-----
3*	Bola / Ball	Acero Inox. / Stainless Steel 1.4408	Pulido / Polish	2907 ($\leq 4''$) 2914 ($\geq 5''$)
4	Eje / Stem	Acero Inox. / Stainless Steel 316	-----	2908
5*	Asiento / Ball seat	PTFE+15% FV / GF	-----	2909
6*	Junta / Gasket	SS+Graphite	-----	2909
7*	Arandela fricción / Thrust washer	PTFE + grafito / graphite	-----	2909
8*	Tórica / O' ring	FPM	-----	2909
9*	Empaquetadura / Stem packing	PTFE	-----	2909
10	Anillo Prensa / Gland	Acero Inox. / Stainless Steel 304	-----	-----
11	Arandela / Spring Washer	Acero Inox. / Stainless Steel 301	-----	-----
12	Tuerca / Nut	Acero Inox. / Stainless Steel 304	-----	-----
13	Trabatuerca / Lock Washer	Acero Inox. / Stainless Steel 304	-----	-----

Nº	Denominación / Name	Material	Acabado Superficial / Surface Treatment	Cód. Recambio Spare Part Code
14	Cuerpo Maneta / Body Handle	Acero Inox. / Stainless Steel 1.4408	Granallado / Shot blasting	-----
15	Maneta / Handle	Acero Inox. / Stainless Steel 304	-----	-----
16	Prisionero / Stud Bolt	Acero Inox. / Stainless Steel 304	-----	-----
17	Tuerca / Nut	Acero Inox. / Stainless Steel 304	-----	-----
18	Espárrago / Stud Bolt	Acero Inox. / Stainless Steel 304	-----	-----
19	Tuerca / Nut	Acero Inox. / Stainless Steel 304	-----	-----
20	Tope / Stopper	Acero Inox. / Stainless Steel 304	-----	-----
21	Arandela / Washer	Acero Inox. / Stainless Steel 304	-----	-----
22	Funda / Handle Sleeve	Vinilo / Vynil	-----	-----

* Piezas que componen los Kit de Reparación / Repair Kit Parts

Dispositivo Antiestático / Antistatic Device

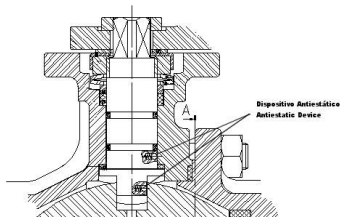

Este dispositivo nos garantiza la continuidad eléctrica entre esfera - eje - cuerpo, esto es de especial necesidad en fluidos inflamables. / *This device provides Ball - Stem - Body of electric continuity. It is specially required with flammable fluids.*

Detalle de la zona de Eje / Stem detail

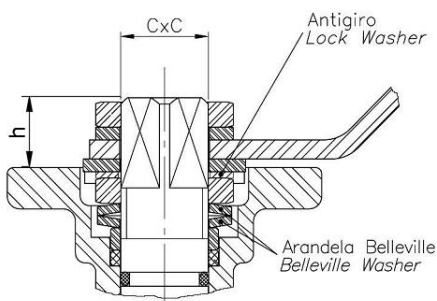

Antigiro / Lock Washer: Previene el desajuste de la tuerca del eje en elevados ciclos de maniobra / *Prevents unthreading of stem nut in high cycle automation applications.*

Arandela Belleville / Belleville Washer: Las arandelas belleville proporcionan una carga constante sobre el prensa asegurando un cierre firme en variaciones de condiciones de trabajo. / *Standard belleville washers provide constant "live load" on the stem seals, assuring a tight seal even varying service parameters*

DIMENSIONES GENERALES / GENERAL DIMENSIONS

Ref	Medida/ Size	DN	PN	Dimensiones / Dimensions (mm)						ISO 5211	Peso/ Weight (Kg)
				D	A	L	M	C x C	h		
2529 10	2 ½"	65	40	185	155	170	380	17 x 17	21	F07/F10	15,950
2529 11	3"	80	40	200	165	180	380	17 x 17	19	F07/F10	20,470
2529 12	4"	100	40	235	180	190	380	17 x 17	19	F07/F10	29,380
2529 13	5"	125	40	270	200	325	600	27 x 27	44	F10/F12	50,000
2529 14	6"	150	40	300	225	350	620	27 x 27	34	F10/F12	71,500

CURVA PRESIÓN TEMPERATURA / PRESSURE TEMPERATURE RATING

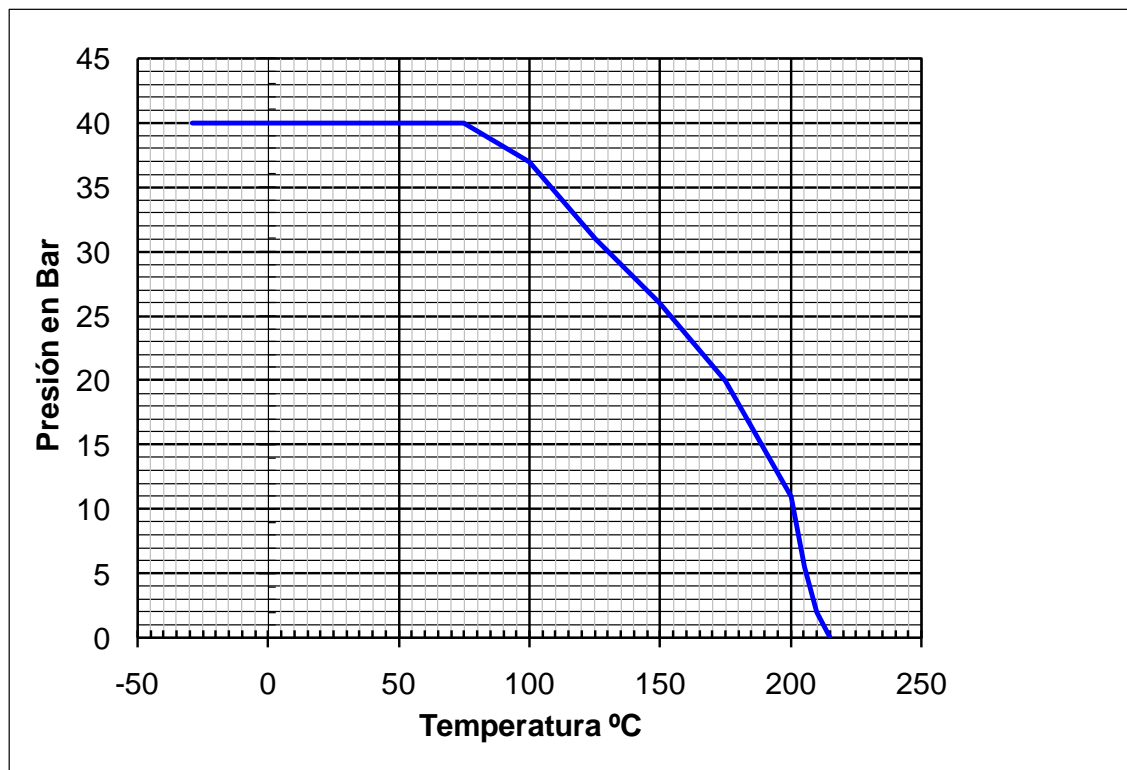

VALORES DE Kv / Kv VALUES

K_v (m^3/h) = Es la cantidad de metros cúbicos por hora que pasará a través de la válvula generando una pérdida de carga de 1 bar.

K_v (m^3/h) = Flow rate of water in cubic meter per hour that will generate a pressure drop of 1 bar across the valve.

2 1/2"	3"	4"	5"	6"
410	900	1450	2150	3700

