

**ARTICULO : 2102 / D2102**  
**Válvula de compuerta con cierre de EPDM**  
**Gate valve with EPDM closing**

### Características

1. Válvula de compuerta con cierre elástico.
2. Construcción en fundición nodular EN-GJS-500 (GGG-50).
3. Compuerta recubierta con EPDM.
4. Vástago no ascendente.
5. Cierre en sentido de las agujas del reloj.
6. Diseño según DIN 3352.
7. Longitud entre caras según DIN 3202 F4.
8. Extremos bridados según DIN 2501 PN 16.
9. Apta para conducción de agua.
10. Paso total, mínima pérdida de carga.
11. Estanqueidad en ambas direcciones.
12. Pares de maniobra reducidos.
13. Recubrimiento interior y exterior con pintura epoxy.
14. Temperatura Máxima de trabajo: 80°C.

### Features

1. Gate valve with elastic closing.
2. Made of Ductile Iron EN-GJS-500 (GGG-50).
3. Wedge coated with EPDM.
4. Non-rising stem.
5. Clockwise for closing the valve.
6. Design according to DIN 3352.
7. Face to Face according to DIN 3202 F4.
8. Flanged ends according to DIN 2501 PN 16.
9. Suitable medium: Water.
10. Full Port, minimum head losses.
11. Bidirectional installation.
12. Reduced torque.
13. Inside & Outside with Epoxy coating.
14. Max. Working temp.: 80°C.

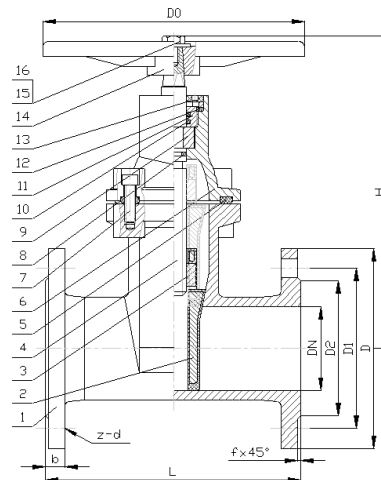

Nº	Denominación / Name	Material	Acabado Superficial / Surface Treatment
1	Cuerpo / Body	Fundición Nodular / Ductile Iron EN-GJS-500	Pintura epoxi / Epoxy coating
2	Compuerta / Wedge Body	Fundición Nodular / Ductile Iron EN-GJS-400 + EPDM	-----
3	Tuerca del Eje / Stem Nut	Latón / Brass CW602N	-----
4	Eje / Stem	AISI 410	-----
5	Junta Cuerpo / Body Gasket	EPDM	-----

Nº	Denominación / Name	Material	Acabado Superficial / Surface Treatment
6	Tapa / Bonnet	Fundición Nodular / Ductile Iron EN-GJS-500	Recubrimiento epoxi / Epoxy coating
7	Tornillo / Screw	Acero Carbono / Carbon Steel	-----
8	Tórica / O'ring	EPDM	-----
9	Separador / Locating Ring	Acero Inoxidable / Stainless Steel	-----
10	Tórica / O'ring	EPDM	-----
11	Tuerca prensaestopas / Packing Nut	Latón / Brass	-----
12	Arandela / Washer	Nylon	-----
13	Tapón anti-polvo / Anti-Dust ring	Plástico ABS / ABS Plastic	-----
14	Volante / Handwheel	Acero Carbono / Carbon Steel	Recubrimiento epoxi / Epoxy coating
15	Arandela / Washer	Acero Carbono / Carbon Steel	Cincado / Zinc PLated
16	Tornillo / Screw	Acero Carbono / Carbon Steel	Cincado / Zinc PLated

## DIMENSIONES GENERALES / GENERAL DIMENSIONS

Ref	Medida / Size	PN	Dimensiones / Dimensions (mm)										Peso / Weight (Kg)
			DN	H	L	D	D0	D1	D2	b	f	z-d	
2102 09	2"	16	50	205	150	165	180	125	99	19	3	4-19	9,5
2102 10	2 ½"	16	65	230	170	185	200	145	118	19	3	4-19	13
2102 11	3"	16	80	255	180	200	200	160	132	19	3	8-19	15
2102 12	4"	16	100	285	190	220	220	180	156	19	3	8-19	19
2102 13	5"	16	125	330	200	250	250	210	184	19	3	8-19	26
2102 14	6"	16	150	370	210	285	250	240	211	19	3	8-23	35
2102 16	8"	16	200	455	230	340	280	295	266	20	3	12-23	57
2102 18	10"	16	250	535	250	400	320	355	319	22	3	12-28	76
2102 20	12"	16	300	620	270	455	350	410	370	24.5	4	12-28	120

## ADAPTADOR OPCIONAL / OPCIONAL ADAPTER ( Ref. D2102 )

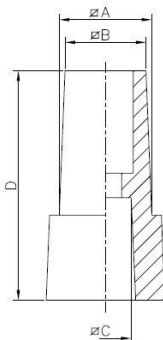

Ref.	Medida / Size	A	B	C	D
D2102 09	2" – 4"	31	29	12.5	45
D2102 13	5" – 6"	31	29	17.5	45
D2102 16	8"	31.5	29	17.5	76
D2102 18	10" – 12"	31.5	29	21.5	76

## VALORES DE $K_v$ / $K_v$ VALUES

$K_v$  = Es la cantidad de metros cúbicos por hora ( $m^3/h$ ) que pasará a través de la válvula generando una pérdida de carga de 1 bar.

$K_v$  = Flow rate of water in cubic meter per hour ( $m^3/h$ ) that will generate a pressure drop of 1 bar across the valve.

DN 50	DN 65	DN 80	DN 100	DN 125	DN 150	DN 200	DN 250	DN 300
250	410	590	1050	1850	2620	4850	7600	11200

