

ARTICULO : 2100 / 2100D

Válvula de compuerta con cierre de EPDM – Extremos ranurados Gate valve with EPDM seat – Grooved ends

Características

1. Válvula de compuerta con cierre elástico.
2. Construcción en fundición nodular EN-GJS-400 (GGG-40).
3. Compuerta en fundición nodular recubierta con EPDM.
4. Husillo ascendente.
5. Cierre en sentido de las agujas del reloj.
6. Diseño según AWWA C515.
7. Longitud entre caras según ASME B16.10.
8. Extremos ranurados según AWWA C606.
9. Estanqueidad en ambas direcciones.
10. Recubrimiento interior y exterior con pintura epoxi RAL 3000
11. Presión máxima de trabajo 300 PSI.
12. Temperatura Máxima de trabajo: 80°C.
13. Certificación UL/FM para aplicación en instalaciones fijas contra incendios.

Features

1. Gate valve with elastic closing.
2. Made by Ductile Iron EN-GJS-400 (GGG-40).
3. Ductile Iron wedge coated EPDM.
4. Rising stem (OS&Y).
5. Clockwise for close valve.
6. Design according to AWWA C515.
7. Face to Face according to ASME B16.10.
8. Grooved ends according to AWWA C606.
9. Bidirectional installation.
10. Inside & Outside with Epoxy coating RAL 3000
11. Max. Working pressure 300 PSI.
12. Max. Working temperature 80°C.
13. UL/FM certification for use in fire protection systems.

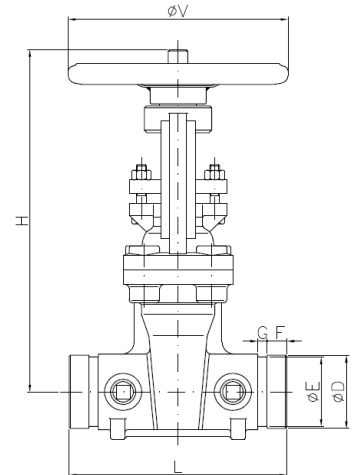
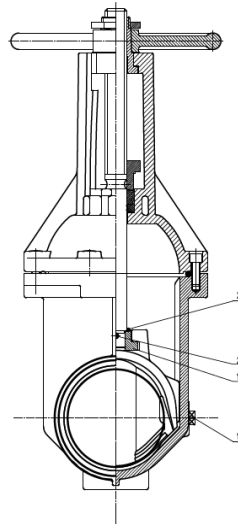
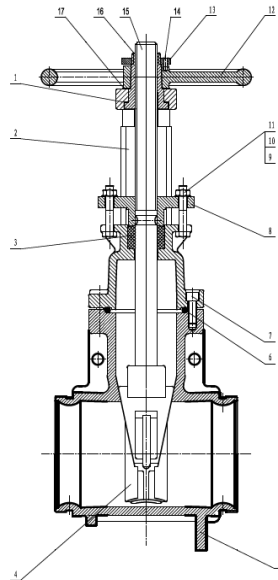

Nº	Denominación / Name	Material	Acabado Superficial / Surface Treatment
1	Junta / Gasket	Acero Inoxidable / S.S.304	-----
2	Tapa / Bonnet	Fundición Nodular / Ductile Iron EN-GJS-400	Pintura epoxi / Epoxy coating
3	Estopada / Packing	Grafito / Graphite	-----

4	Compuerta / <i>Wedge Body</i>	Fundición Nodular / <i>Ductile Iron EN-GJS-400 + EPDM</i>	-----
5	Cuerpo / <i>Body</i>	Fundición Nodular / <i>Ductile Iron EN-GJS-400</i>	Pintura epoxi / <i>Epoxy coating</i>
6	Junta Cuerpo / <i>Body Gasket</i>	EPDM	-----
7	Tornillo / <i>Bolt</i>	AISI 304	-----
8	Prensaestopas / <i>Gland</i>	Fundición Nodular / <i>Ductile Iron EN-GJS-400</i>	Pintura epoxi / <i>Epoxy coating</i>
9	Tuerca / <i>Nut</i>	AISI 304	-----
10	Arandela / <i>Washer</i>	AISI 304	-----
11	Tornillo / <i>Bolt</i>	AISI 304	-----
12	Volante / <i>Handwheel</i>	Fundición Nodular / <i>Ductile Iron EN-GJS-400</i>	Pintura epoxi / <i>Epoxy coating</i>
13	Traba tuerca / <i>Lock Nut</i>	Acero Carbono / <i>Carbon Steel</i>	-----
14	Tornillo fijación / <i>Locating screw</i>	AISI 304	-----
15	Eje / <i>Stem</i>	AISI 304	-----
16	Tuerca del Eje / <i>Stem Nut</i>	C95400	-----
17	Junta / <i>Gasket</i>	C95400	-----
18	Tapon / <i>Plug</i>	C95400	-----
19	Tuerca de arrastre / <i>Lifting nut</i>	C95400	-----
20	Perno / <i>Pin</i>	AISI 304	-----
21	Tórica / <i>O'ring</i>	EPDM	-----

DIMENSIONES GENERALES / GENERAL DIMENSIONS

Ref.	Medida / Size	Dimensiones / <i>Dimensions (mm)</i>						
		L	D	E	F	G	H	V
2100 10	2 ½"	190	73 (*)	69.1	15.9	7.9	370	185
2100D 10	DN 65		76.1 (**)	72.3				
2100 11	3"	203	88.9	84.9	15.9	7.9	420	256
2100 12	4"	229	114.3	110.1	15.9	9.5	447	256
2100 13	5"	254	141.3 (*)	137	15.9	9.5	547	310
2100D 13	DN 125		139.7 (**)	135.5				
2100 14	6"	267	168.3 (*)	164	15.9	9.5	607	310
2100D 14	DN 150		165.1 (**)	160.8				
2100 16	8"	292	219.1	214.4	19	11.1	754	355
2100 18	10"	330	273	268.3	19	12.7	890	446
2100 20	12"	356	323.9	318.3	19	12.7	1031	446

(*) Para tubo / *For Pipe: ASME B 36.10*
(**) Para tubo / *For Pipe: UNE-EN 10255*